

# Year 6 SATs Booster

## Maths 1

### Word Problems

## **Objectives:**

- **Using tables to work out other facts.**
- **Solve word problems.**
- **Solve simple problems about ratio and proportion.**

## **Mental mathematics questions**

**1** Multiply twelve by forty.

$$12 \times 40$$

How can we do this?

# Mental mathematics questions

1 Multiply twelve by forty.

One method

$$12 \times 40$$

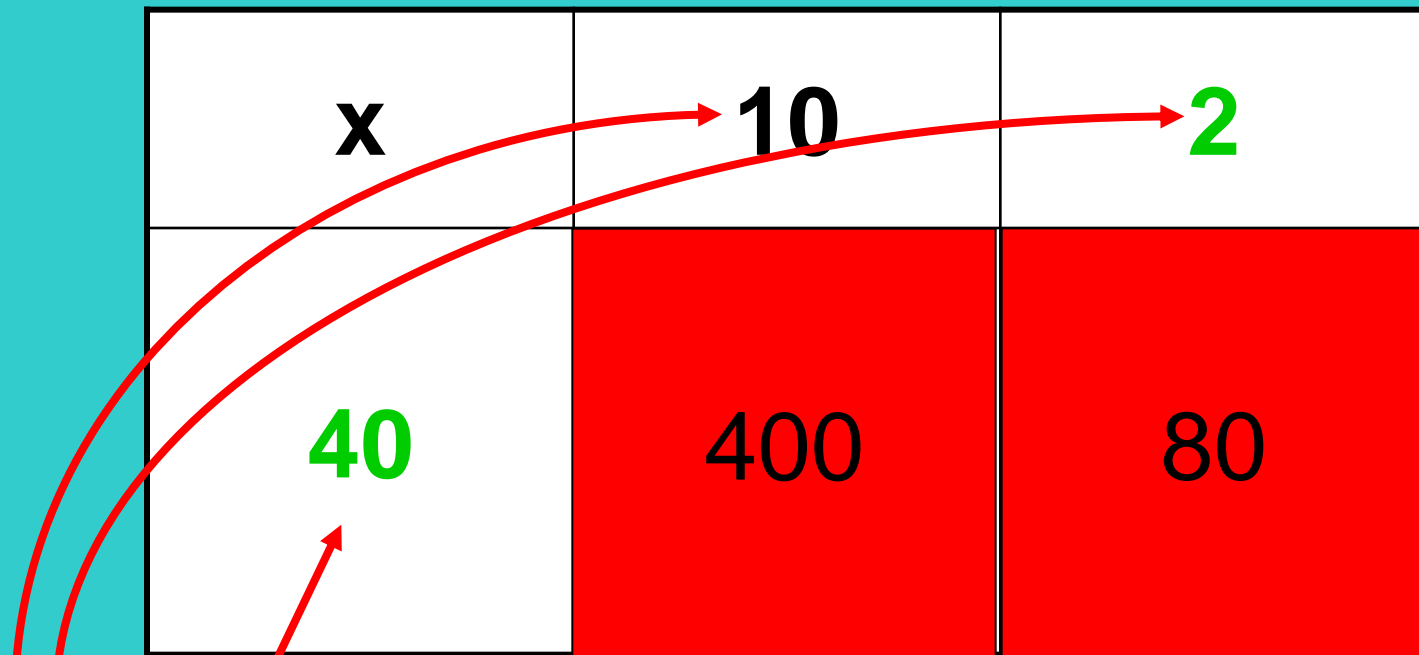

A total of 480

# Mental mathematics questions

1 Multiply twelve by forty.

Another method

$$12 \times 4 \times 10$$

$$12 \times 2 \times 2 \times 10$$

**480**

# Mental mathematics questions

2 What is forty-eight divided by **six**?

What multiplication in the 6 times-table is this connected to?

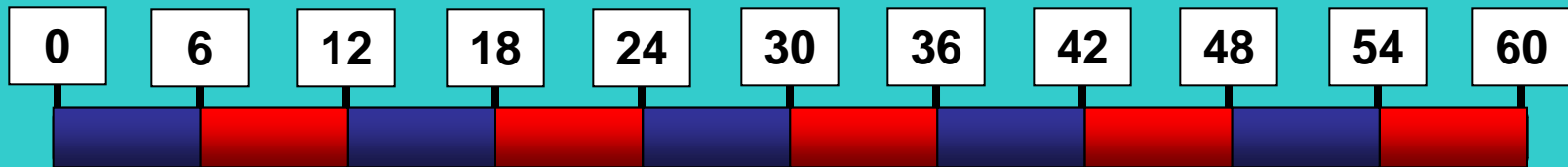

## Mental mathematics questions

2 What is **forty-eight** divided by **six**?

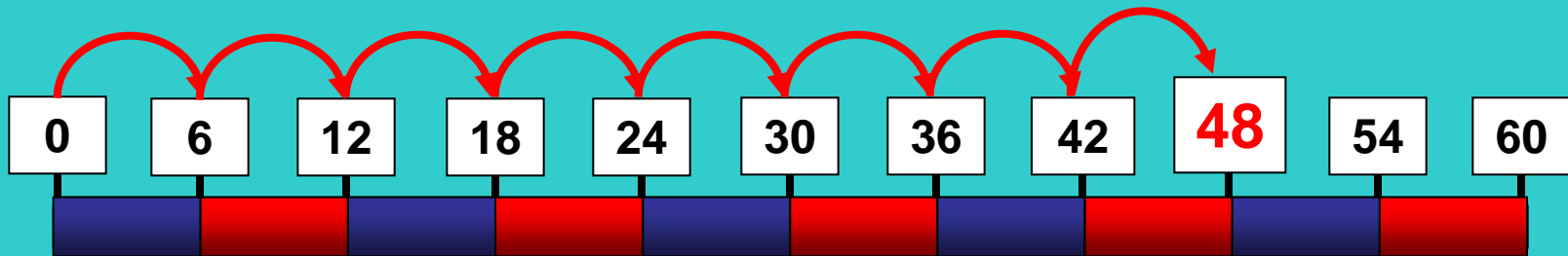

**48 is 6 times 8**

## Times-tables connections:

Knowing your times-tables and the inverse connections (divisions) is **very** helpful.

$$8 \times 6 = 48$$

$$6 \times 8 = 48$$

$$48 \div 6 = 8$$

$$48 \div 8 = 6$$

## Times-tables connections:

### Mental mathematics questions

2 What is forty-eight divided by six?

$$6 \times 8 = 48$$

so

there are **eight** 6's in 48

$$48 \div 6 = 8$$

Which means **forty-eight**  
**divided by six is eight**

## Mental mathematics questions

3 What is eighteen divided by three?

$$18 \div 3$$

What is the times-table that is needed for this problem?

The three times-table is needed for this problem

## Mental mathematics questions

3 What is eighteen divided by three?

$$3 \times 6 = 18$$

$$18 \div 3 = 6$$

Which means **eighteen**  
divided by three is **six**

## **Mental mathematics questions**

**4** What is one **quarter** of twenty-four?

What is the times-table that is needed for this problem?

## Mental mathematics questions

4 What is one **quarter** of twenty-four?

$$4 \times 6 = 24$$

$$24 \div 4 = 6$$

Which means **twenty-four**  
divided by four is **six**

## Mental mathematics questions

5 How many five-pence coins make thirty-five pence?

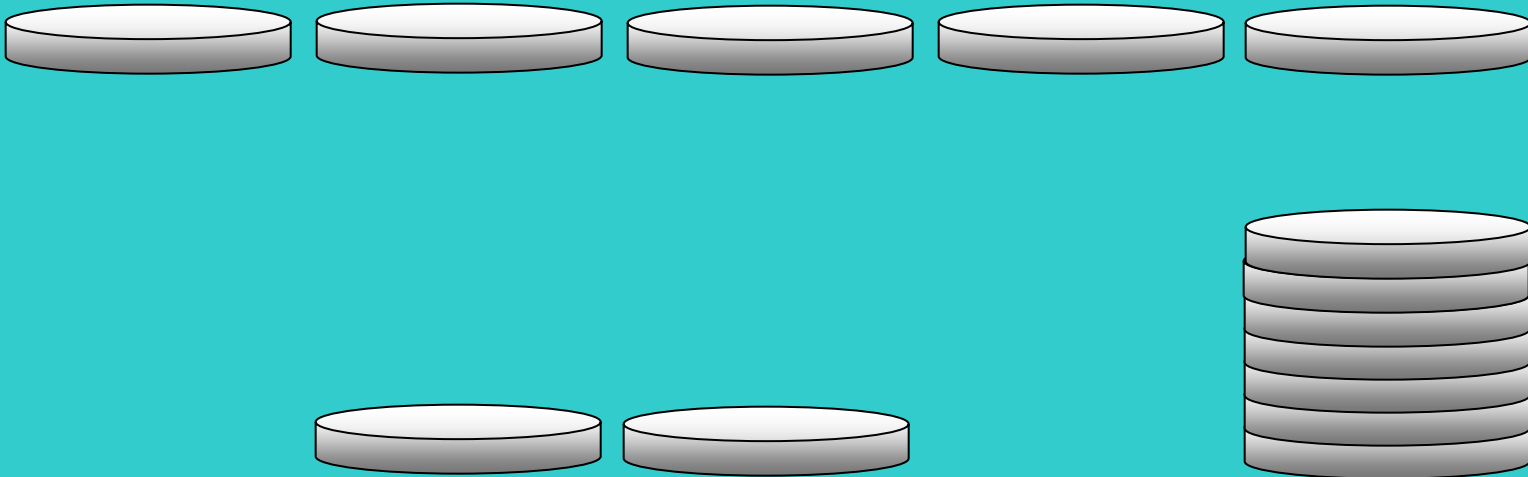

# Mental mathematics questions

5 How many five-pence coins make thirty-five pence?

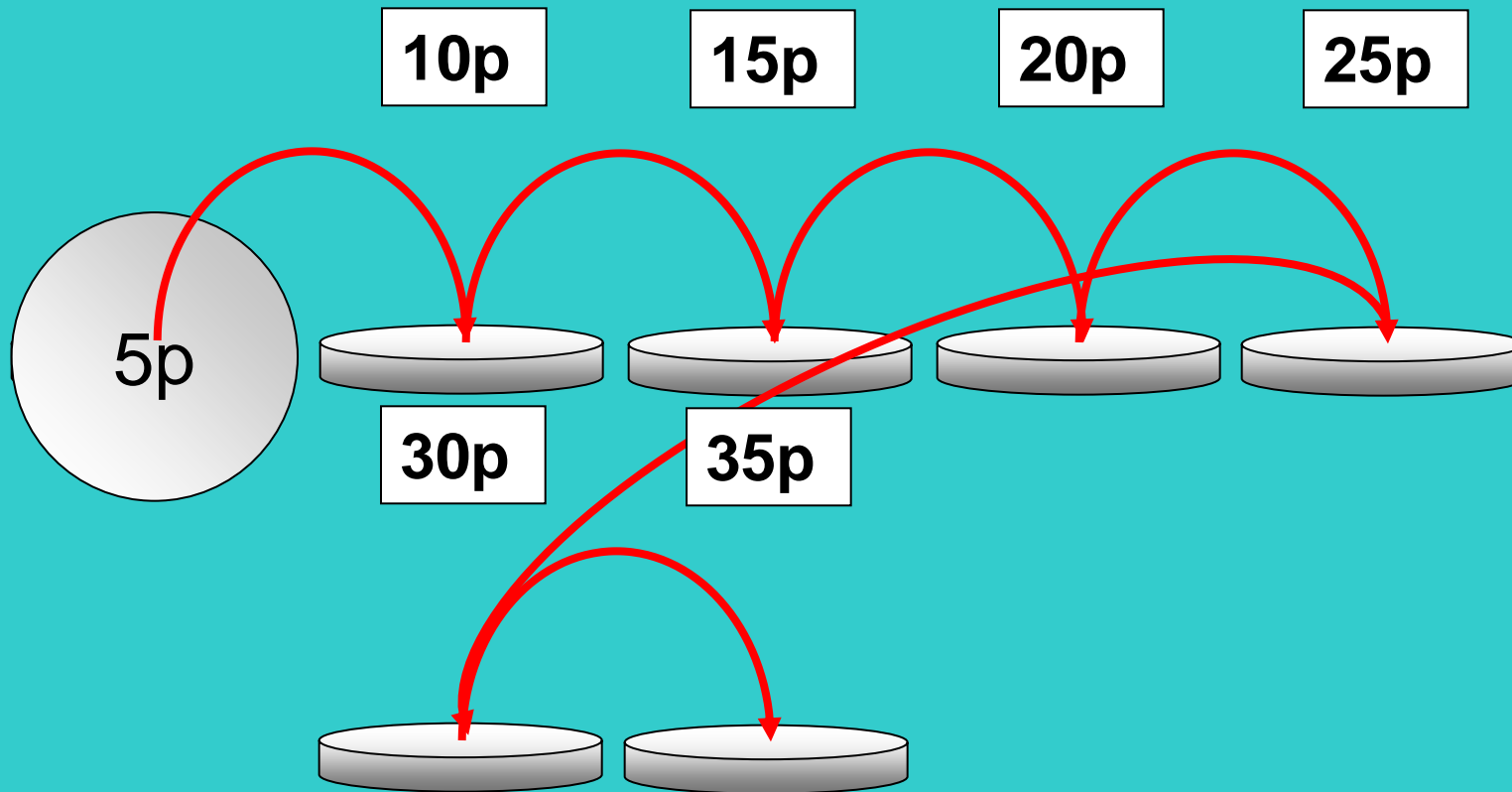

## Mental mathematics questions

5 How many five-pence coins make thirty-five pence?

$$5 \times 7 = 35$$

7 five-pence coins  
make thirty-five pence

$$35 \div 5 = 7$$

35p

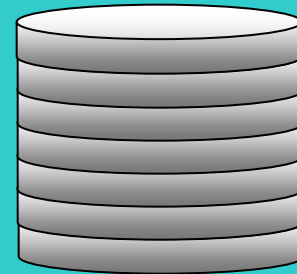

## Mental mathematics questions

6 A pen costs two pounds forty-seven. I buy two pens.

How much change do I get from ten pounds?

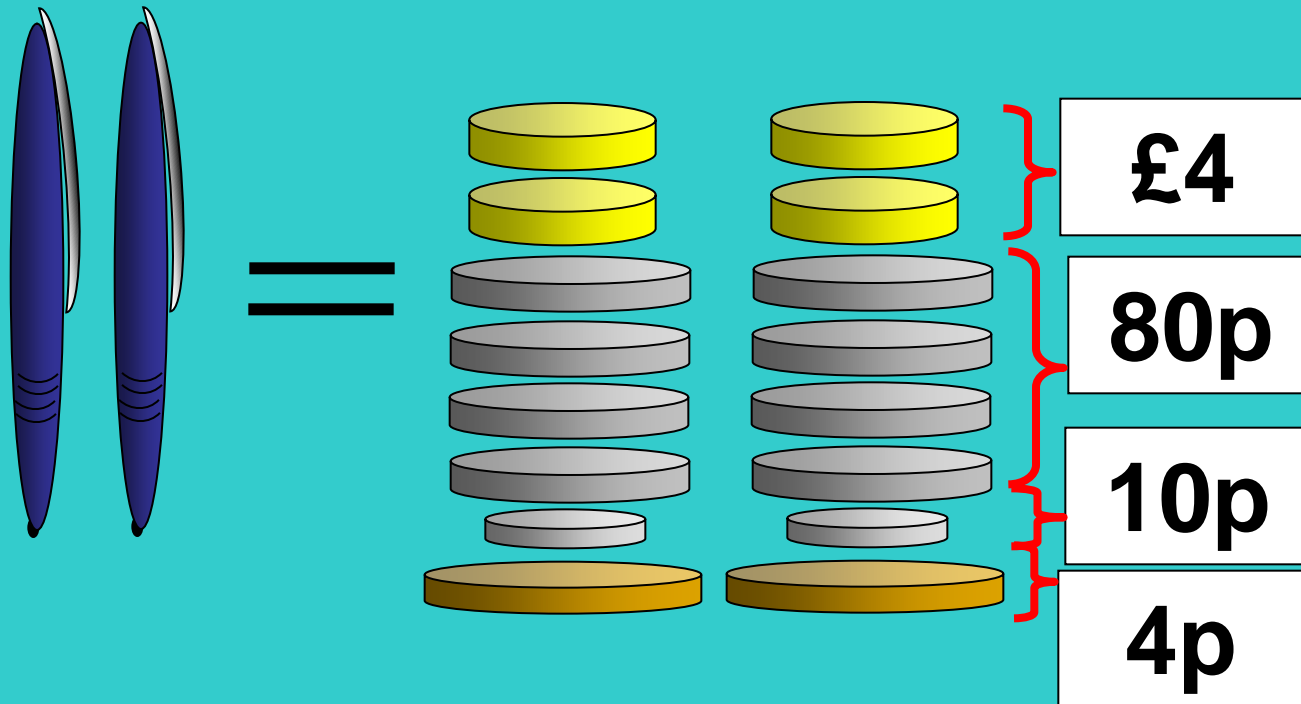

## Mental mathematics questions

6 A pen costs two pounds forty-seven. I buy two pens.

How much change do I get from ten pounds?

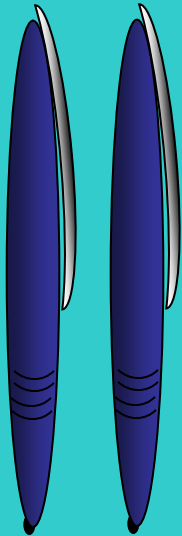

=

£4.94

£4

80p

10p

4p

## Mental mathematics questions

6 A pen costs two pounds forty-seven. I buy two pens.

How much change do I get from ten pounds?

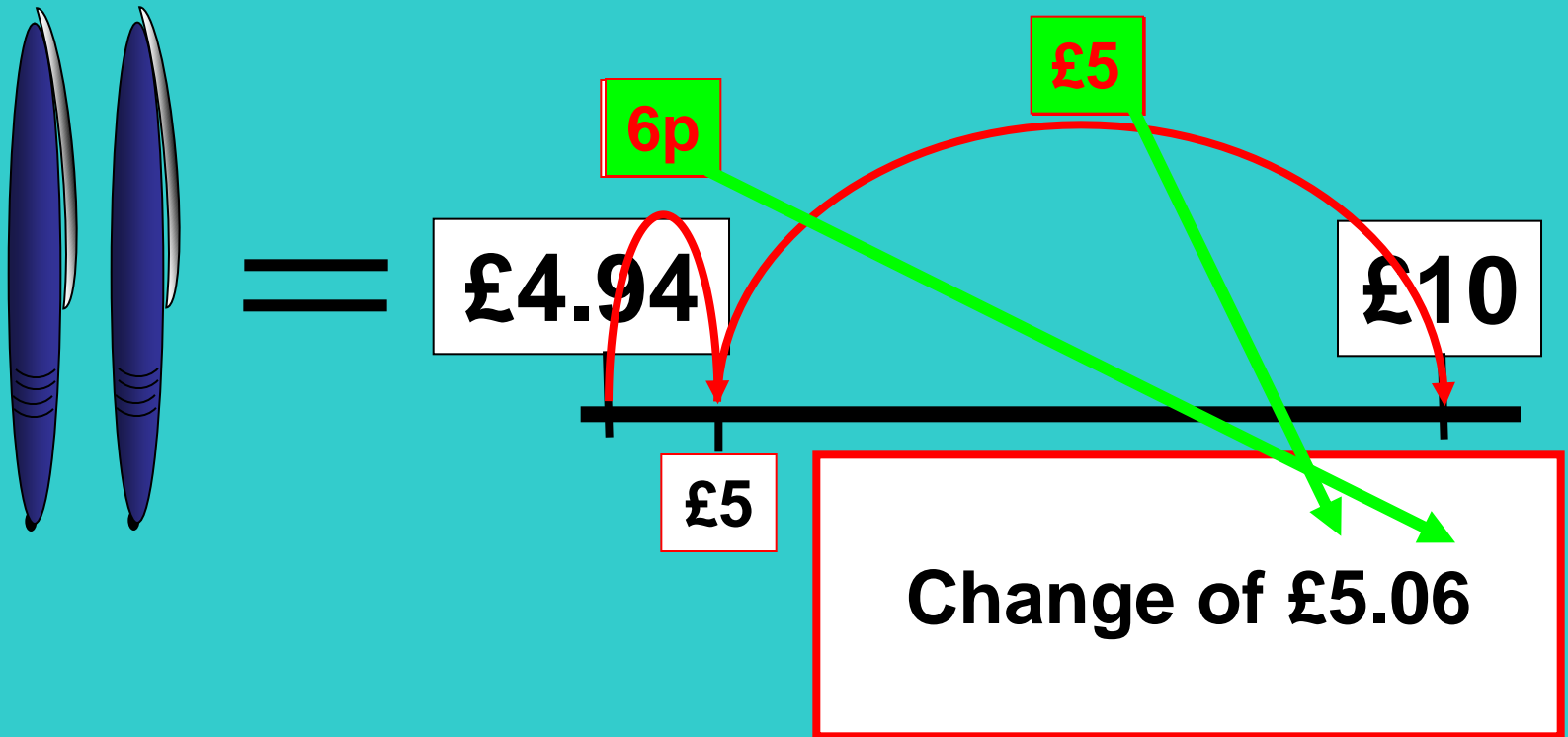

## **Mental mathematics questions**

**7** What is the cost of four birthday cards at one pound and five pence each?

**8** What is the cost of five cassettes at one pound ninety-nine pence each?

**9** A tape costs three pounds ninety-nine. How much would five of these tapes cost?

Think about each one, draw a picture if it helps and use what you know of times-tables to work out the answer...

## Mental mathematics questions

7 What is the cost of five birthday cards at two pounds and nine pence each?

<b>x</b>	<b>£2</b>	<b>9p</b>
<b>5</b>		

## Mental mathematics questions

7 What is the cost of five birthday cards at two pounds and nine pence each?

<b>x</b>	<b>£2</b>	<b>9p</b>
<b>5</b>	<b>£10</b>	<b>45p</b>

**Answer £10.45**

## Mental mathematics questions

8 What is the cost of four books at **one pound ninety-eight pence** each?

$$\text{£}1.98 + 2\text{p} = \text{£}2$$

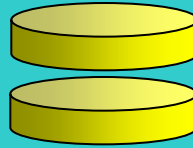

X 4

$$\text{£}2 \times 4 = \text{£}8$$

But we did 4 x 2p too much... 8p

$$\text{£}8 - 8\text{p} = \text{£}7.92$$

## Written approaches

9 A group of 238 people is going on a coach trip.  
Each coach can carry 48 people.  
How many coaches are needed?

Think about what this means.

Draw a picture if it helps...

## Written approaches

9 A group of **238** people is going on a coach trip.  
**Each coach can carry 48 people.**  
How many coaches are needed?

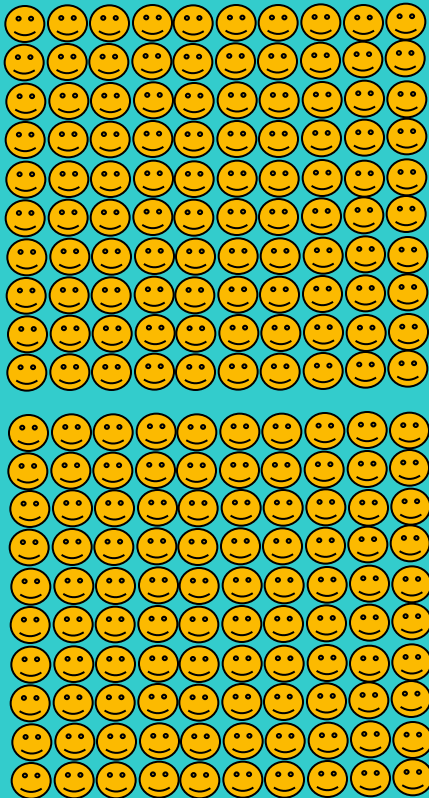

## Written approaches

9 A group of **238** people is going on a coach trip.  
**Each coach can carry 48 people.**  
How many coaches are needed?

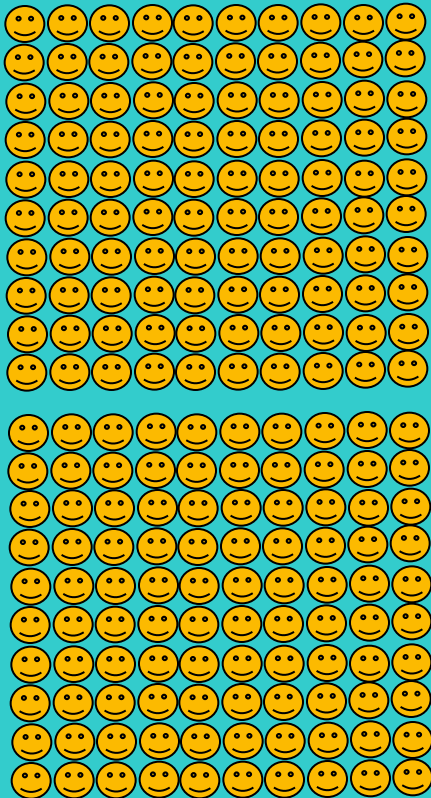

2 coaches can  
carry 96 people

so

4 coaches can  
carry 192 people

## Written approaches

9 A group of **238** people is going on a coach trip.  
**Each coach can carry 48 people.**  
How many coaches are needed?

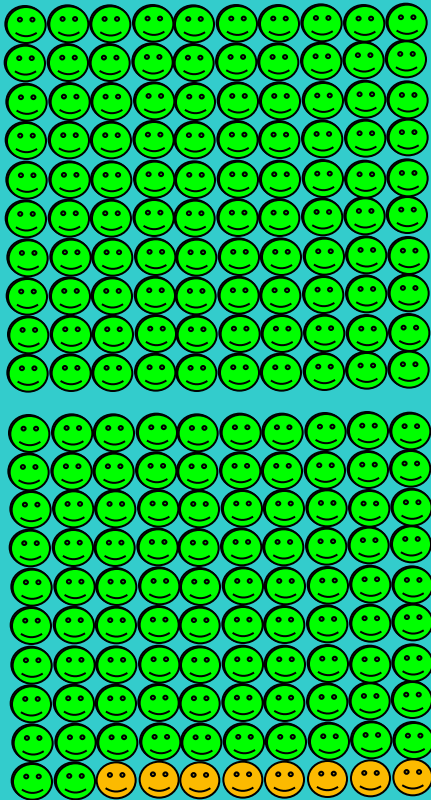

2 coaches can  
carry 96 people  
so  
4 coaches can  
carry **192** people

## Written approaches

9 A group of **238** people is going on a coach trip.  
**Each coach can carry 48 people.**  
How many coaches are needed?



38 people

and

8 people

equals 46 people



## Written approaches

9 A group of **238** people is going on a coach trip.  
**Each coach can carry 48 people.**  
How many coaches are needed?

238

192 -

46

$$4 \times 48 = 192$$

Remainder 46

The extra coach is needed for the last 46 people

**5 coaches**

## Written approaches

**10** Six friends went to a football match.  
The total cost of the tickets for the group  
was £81.

How much would the tickets cost for eight people?

Ticket 45671 /####nmsdwr

Liverpool FC v  
Manchester United FC

Six tickets cost £81.  
We need to find the cost of eight

Six tickets cost £81.  
We need to find the cost of eight

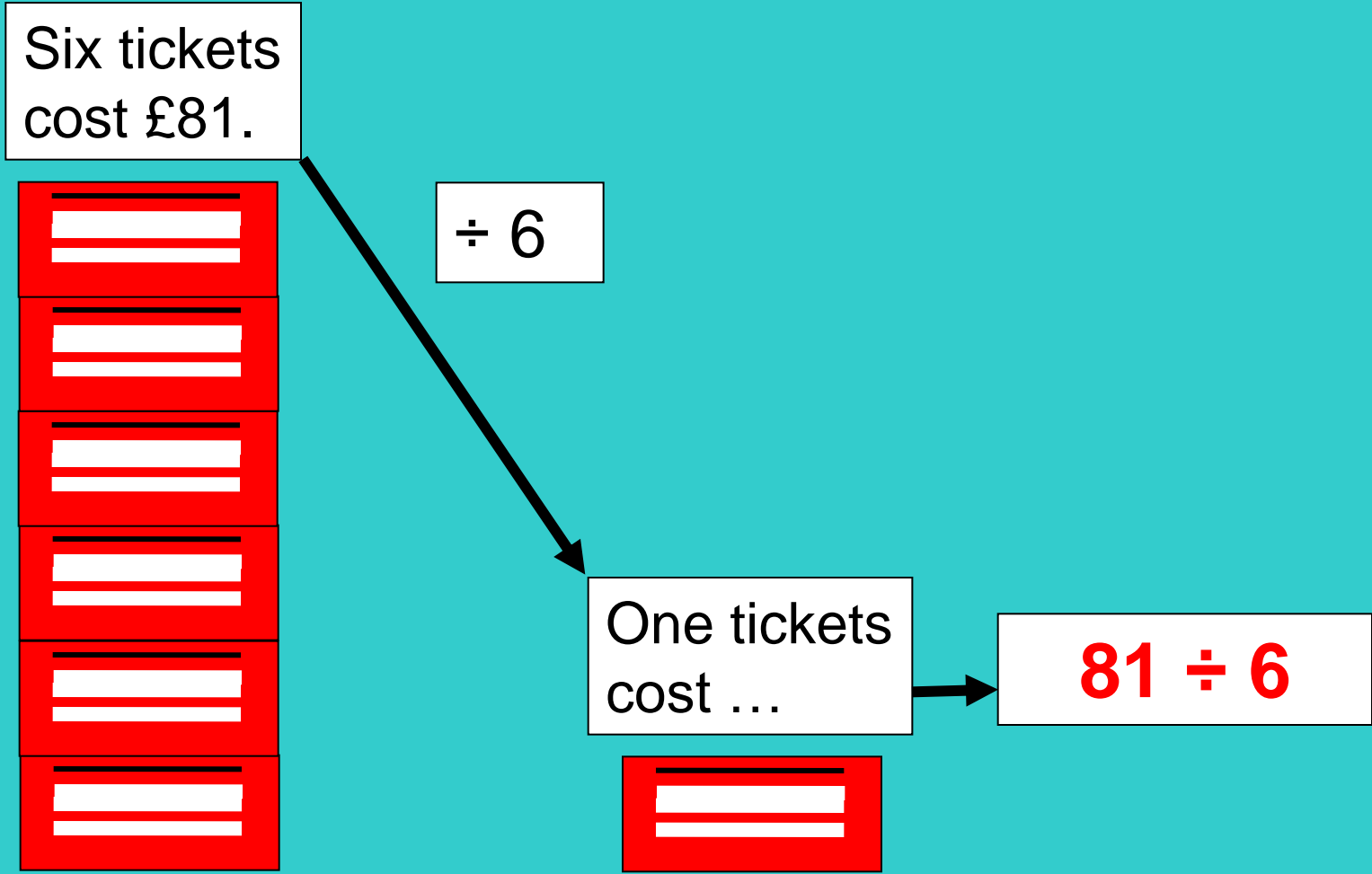

$$81 \div 6$$

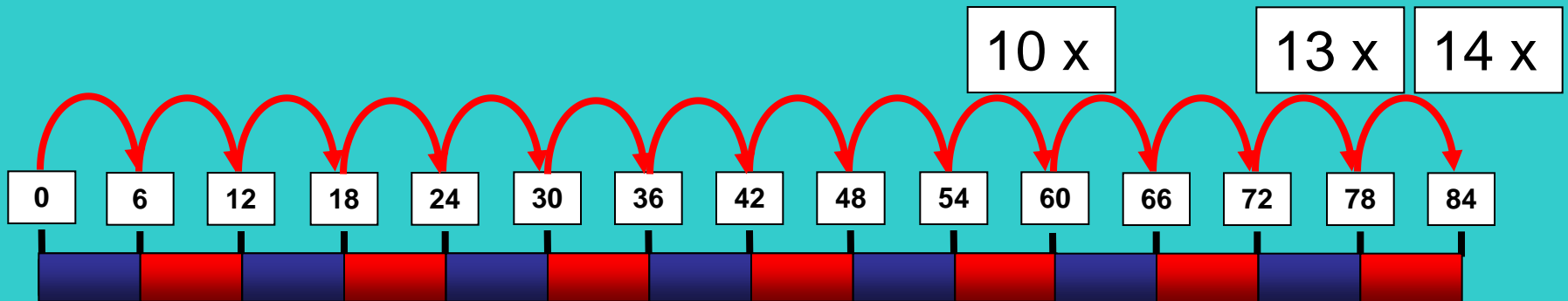

81 is between  $13 \times 6$  and  $14 \times 6$ ...

$6 \times 13 = 78$  so that's

$6 \times \text{£}13 = \text{£}78$

$\text{£}81 - \text{£}78 = \text{£}3$

$\text{£}3 \div 6 = 50\text{p}$

Each ticket costs  $\text{£}13.50$

6 x 10 = 60 so that's

$$6 \times \text{£}10 = \text{£}60 \quad \text{£}10$$

$$\text{£}81 - \text{£}60 = \text{£}21$$

$$6 \times \text{£}3 = \text{£}18 \quad \text{£}3$$

$$\text{£}21 - \text{£}18 = \text{£}3$$

$$6 \times 50\text{p} = \text{£}3 \quad 50\text{p}$$

$$\text{Each ticket costs} \quad \text{£}13.50$$

Six tickets cost £81.  
We need to find the cost of eight

Eight tickets  
cost ...

Six tickets  
cost £81.

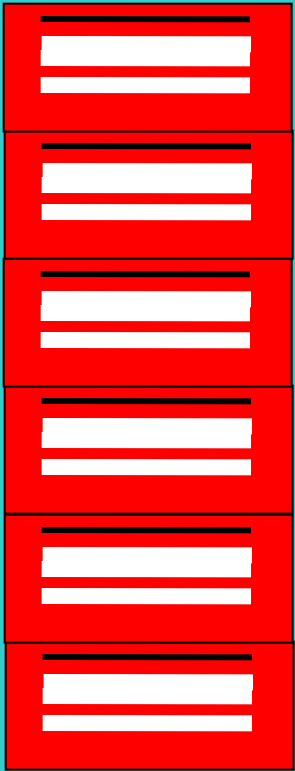

$\div 6$

$\times 8$

One tickets  
cost £13.50

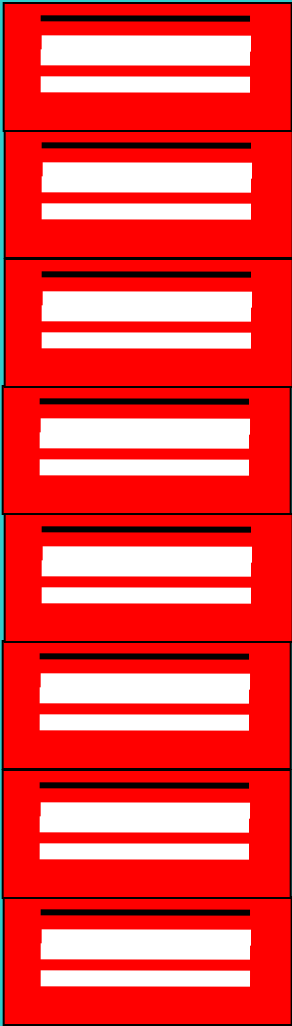

Six tickets cost £81.  
We need to find the cost of eight

**Eight tickets  
cost £108**

Six tickets  
cost £81

**x 2**  
Two tickets  
cost £27

One ticket  
costs £13.50

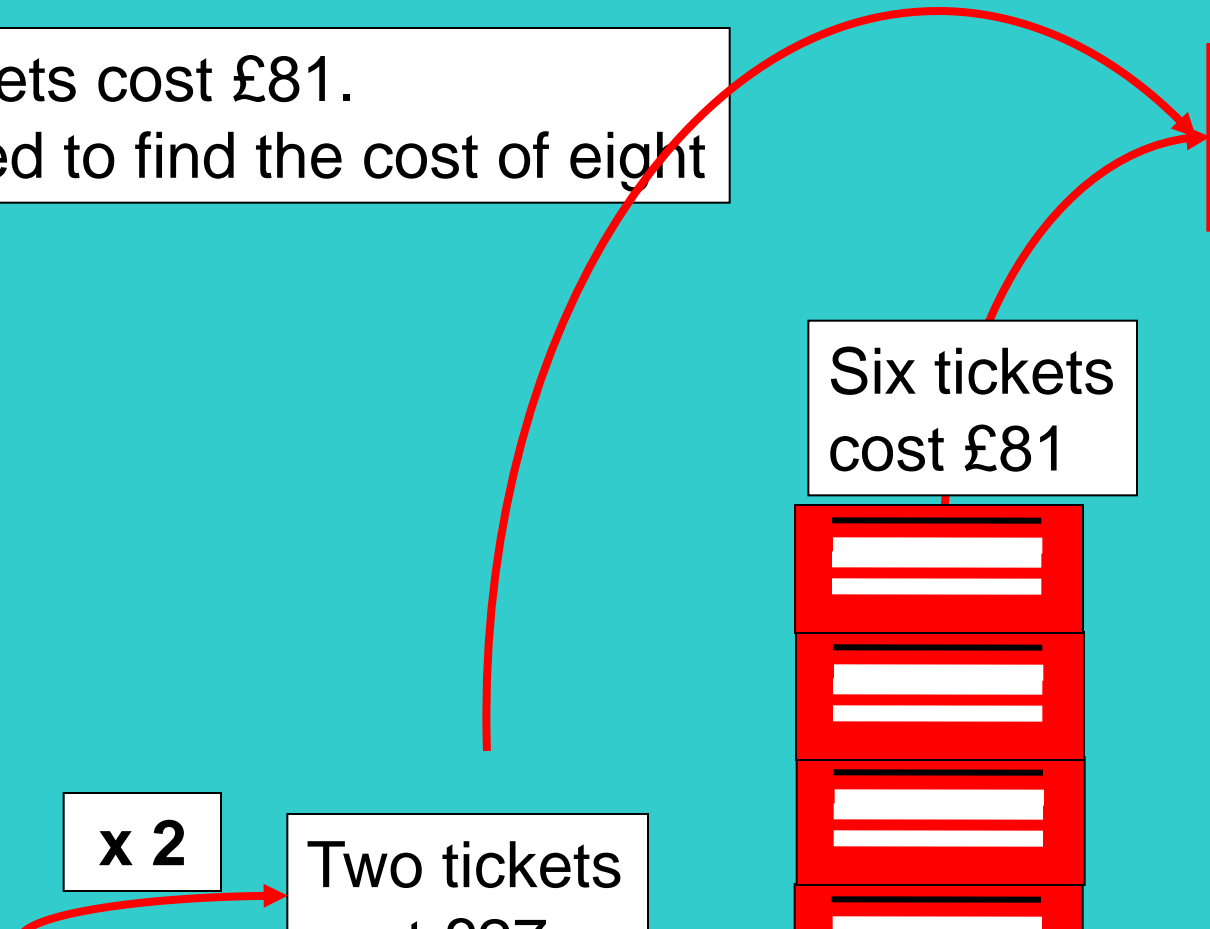
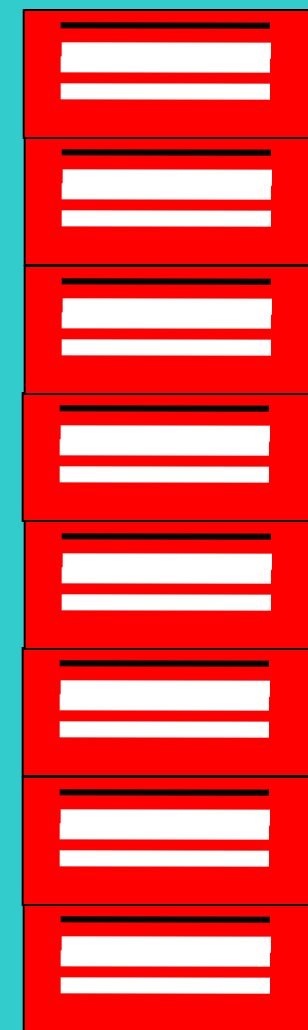
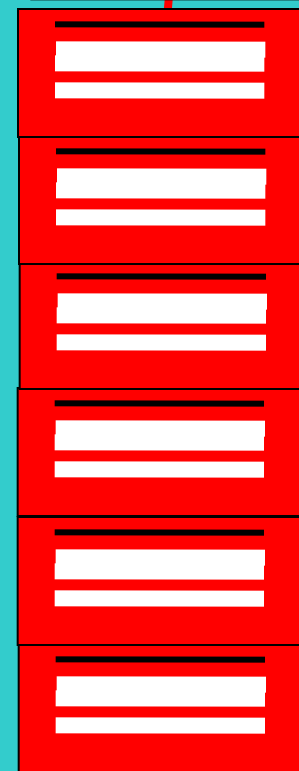
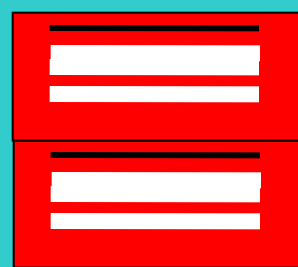

## **Written approaches**

11 The sum of two prime numbers is 14.  
What are the numbers?

**First, what are prime numbers?**

**Prime numbers are numbers  
that only have two factors.**

**You need to know all of them  
up to at least 30...**

## **Written approaches**

11 The sum of two prime numbers is 14.  
What are the numbers?

**2      3      5      7      11      13      17      19      23      29**

**Why aren't 4 or 9 prime numbers?**

**4 has factors of 1, 2, and 4.**

**9 has factors of 1, 3 and 9.**

## Written approaches

11 The **sum of two prime numbers is 14.**  
What are the numbers?

2      3      5      7      11      13      17      19      23      29

**$11 + 3 = 14$  correct**

## Written approaches

- 12** For every thirty people in a company, twelve of them are under twenty years old. There are two-hundred and forty people in the company. How many of them are under twenty years old?

Can you draw a diagram to help think about the question?

## Written approaches

- 12** For every thirty people in a company, twelve of them are under twenty years old.  
There are two-hundred and forty people in the company.  
How many of them are under twenty years old?

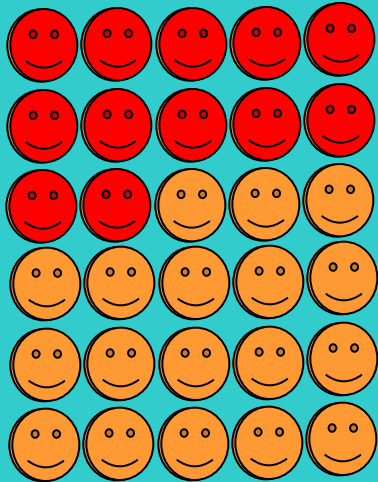

For every thirty people in a company...

twelve of them are under twenty years old

## Written approaches

**12** For every thirty people in a company, twelve of them are under twenty years old.

**There are two-hundred and forty people in the company.**

How many of them are under twenty years old?

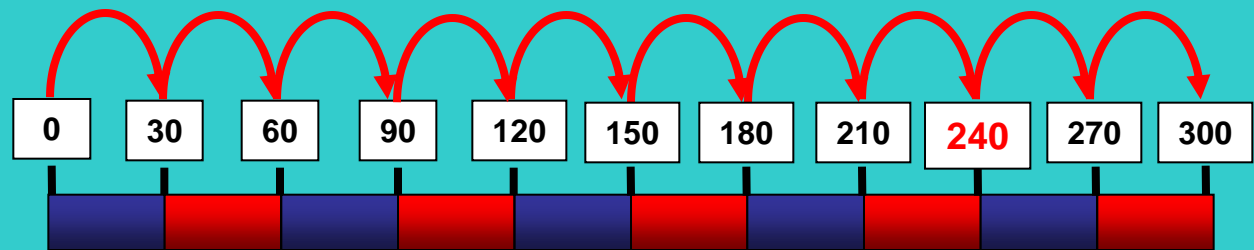
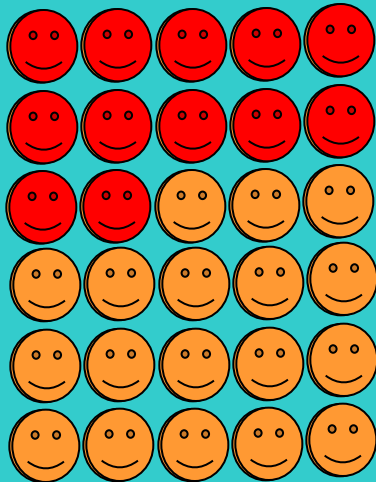

Eight lots of thirty people

## Written approaches

**12** For every thirty people in a company, twelve of them are under twenty years old.

**There are two-hundred and forty people in the company.**

How many of them are under twenty years old?

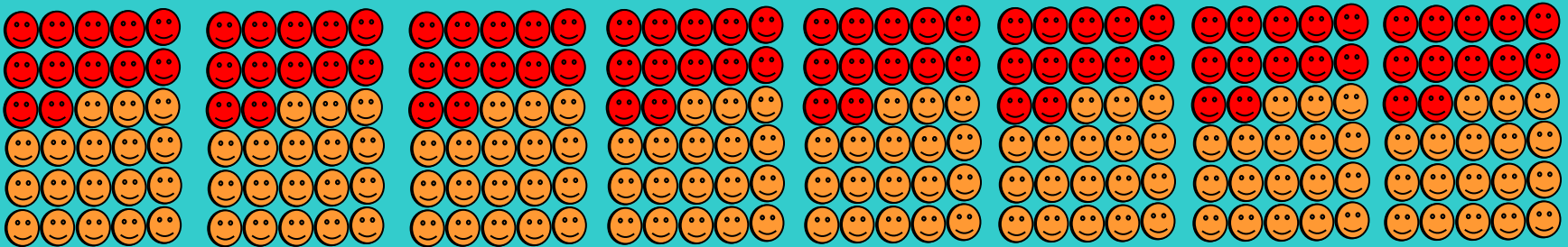

Eight lots of thirty people

## Written approaches

**12** For every thirty people in a company, twelve of them are under twenty years old.

**There are two-hundred and forty people in the company.**

How many of them are under twenty years old?

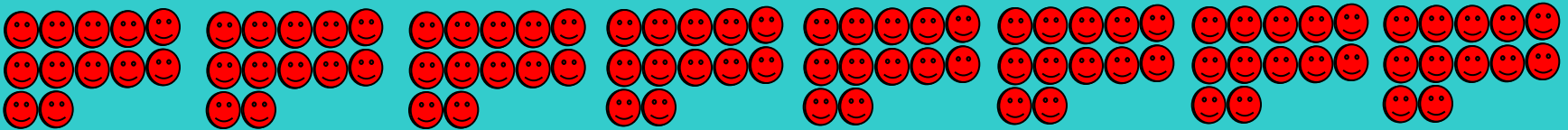

x	10	2
8	80	16

**= 96**

**Eight lots of twelve people**

## **Written approaches**

**12** For every thirty people in a company, twelve of them are under twenty years old.

**There are two-hundred and forty people in the company.**

How many of them are under twenty years old?

**There are ninety-six people under twenty years old.**

# Good ideas for solving word problems...

- Think about what the question means – underline key words.
- Don't just look at the numbers and try the first calculation that comes to mind.
- Draw a simple picture of what you think is happening.
- When you have an answer, think -  
**'Does it make sense?'**

# How to solve problems

## Stage 1 Make sense of the problem

- Read the problem.
- Underline key information.
- Decide what you need to find out.
- Is any information not needed?
- **Don't** just look at the numbers and try the first calculation that comes into your mind.
- If you need to, draw a simple picture of what you think is happening.

## Stage 2 Calculate the answer

- Decide what you need to calculate.
- Should the calculation be done
  - mentally?
  - using a written method?
- Show the working, if appropriate.

## Stage 3 Check the answer

- Write down a solution to the problem.
- Look back at the original problem and make sure the answer makes sense.

# RUCSAC

1) Read



2) Underline



3) Calculation?



4) Solve



5) Answer



6) Check

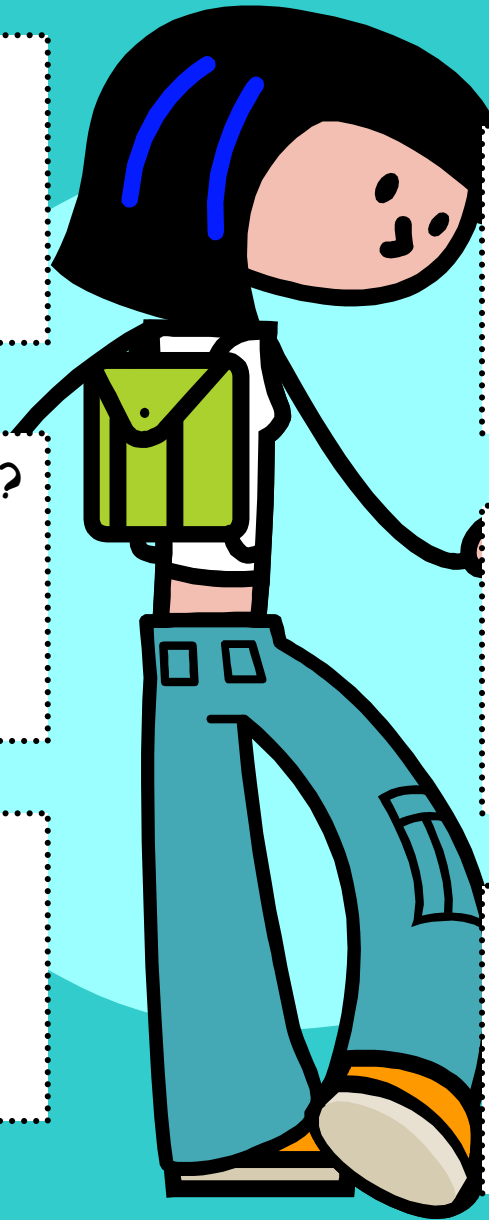

## More complicated word problems:

1. This formula tells you how tall a boy is likely to grow.

Add the mother's and the father's heights. Divide by two.  
Add 7cm to the result.

A boy is likely to grow to this height, plus or minus 10 cm

Marc's mother is 168cm tall and his father is 194cm tall.  
What is the greatest height that Marc is likely to grow?

2. A drink and a box of popcorn costs 90p. Two drinks and a box of popcorn costs £1.45. What does a box of popcorn cost?

3. In a country dance there are 7 boys and 6 girls in every line. 42 boys take part in the dance. How many girls take part?

## Answers:

1. This formula tells you how tall a boy is likely to grow.

Add the mother's and the father's heights. Divide by two. Add 7cm to the result.

A boy is likely to grow to this height, plus or minus 10 cm

Marc's mother is 168cm tall and his father is 194cm tall. What is the greatest height that Marc is likely to grow?

$$168 + 194 = 362\text{cm}$$

$$362 \div 2 = 181$$

$$181 + 7 = 188$$

Marc will grow plus or minus 10cm of this height.

178 to 198 cm

The greatest height Marc is likely to grow is 198cm.

2. A drink and a box of popcorn costs 90p. Two drinks and a box of popcorn costs £1.45. What does a box of popcorn cost?

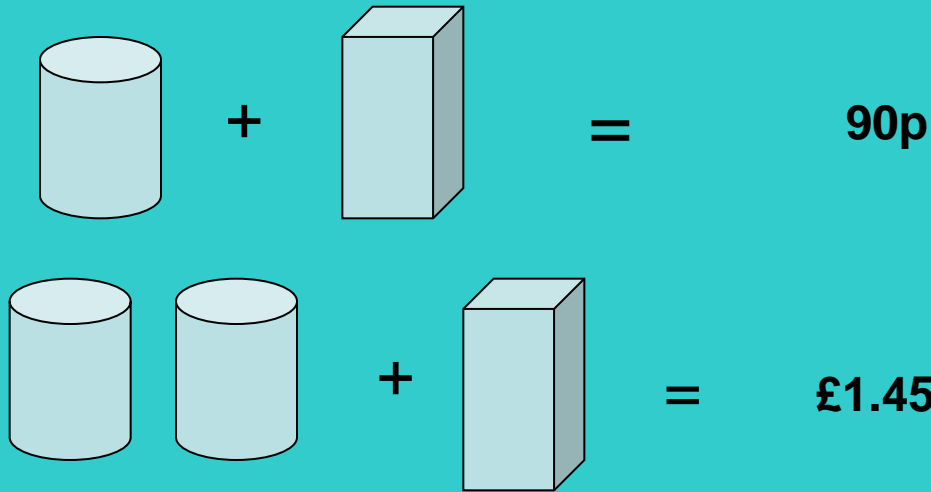

One extra drink  
makes a  
difference of 55p.

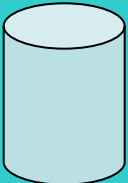
So:  Costs 55p

 Costs  $90\text{p} - 55\text{p} = 35\text{p}$

**Answer: Popcorn costs 35p**

3. In a country dance there are 7 boys and 6 girls in every line. 42 boys take part in the dance. How many girls take part?

**BBBBBBB GGGGGG**

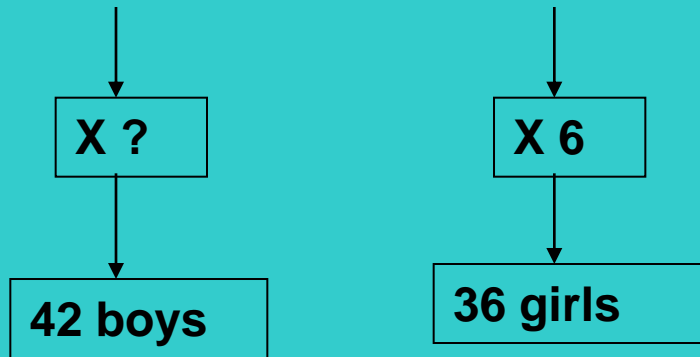

**Answer: 36 girls took part**

## More Problems:

1. A square has an area of  $100\text{cm}^2$ . What is its perimeter?  
Show your working.

2. The price of a pair of jeans was decreased by 10% in a sale. Two weeks later the price was increased by 10%. The final price is not the same as the original price – explain why.

3. Every morning Ramesh catches a school bus at 8:05 a.m. It arrives at school at 8:40 a.m.. Each Friday, the bus takes longer and it arrives at 8:55 a.m.. How long does Ramesh spend coming to school over a school week, a term of 16 weeks, a year of 39 weeks?

1. A square has an area of  $100\text{cm}^2$ . What is its perimeter?  
Show your working.

Area  $100\text{cm}^2$  then side is  $\sqrt{100} = 10\text{cm}$

Side length  $10\text{cm}$  , four equal sides so:

Perimeter is  $4 \times 10\text{cm} = 40\text{cm}$

2. The price of a pair of jeans was decreased by 10% in a sale. Two weeks later the price was increased by 10%. The final price is not the same as the original price – explain why.

Original price of jeans, say is £100

10% reduction means they go down to £90.

After two weeks this price goes up 10% -  $\text{£}90 + 10\% = \text{£}90 + \text{£}9 = \text{£}99$

Why? The 10% decrease is from £100 the 10% increase is from £90.

3. Every morning Ramesh catches a school bus at 8:05 a.m. It arrives at school at 8:40 a.m.. Each Friday, the bus takes longer and it arrives at 8:55 a.m.. How long does Ramesh spend coming to school over a school week, and in a term of 16 weeks?

**Monday to Thursday: 8:05 to 8:40 is 35 minutes**

**Friday: 8:05 to 8:55 is 50 minutes.**

**Total time in one week is:**

$$4 \times 35 \text{ minutes} + 1 \times 50 \text{ minutes} = 140 + 50 = 190 \text{ minutes}$$
$$= 3 \text{ hours } 10 \text{ minutes}$$

**Total time in a term of 16 weeks is:**

$$16 \times 190 \text{ minutes} = 3040 \text{ minutes} \quad 3040 \div 60 = 50.6666\dots$$

hours

$$50 \text{ hours} + 0.6666 \text{ of an hour} = 50 \text{ hrs} + 0.6666 \times 60$$

minutes

$$= 50 \text{ hours } 40 \text{ minutes}$$

## Presents

Gurmit paid £21 for five presents

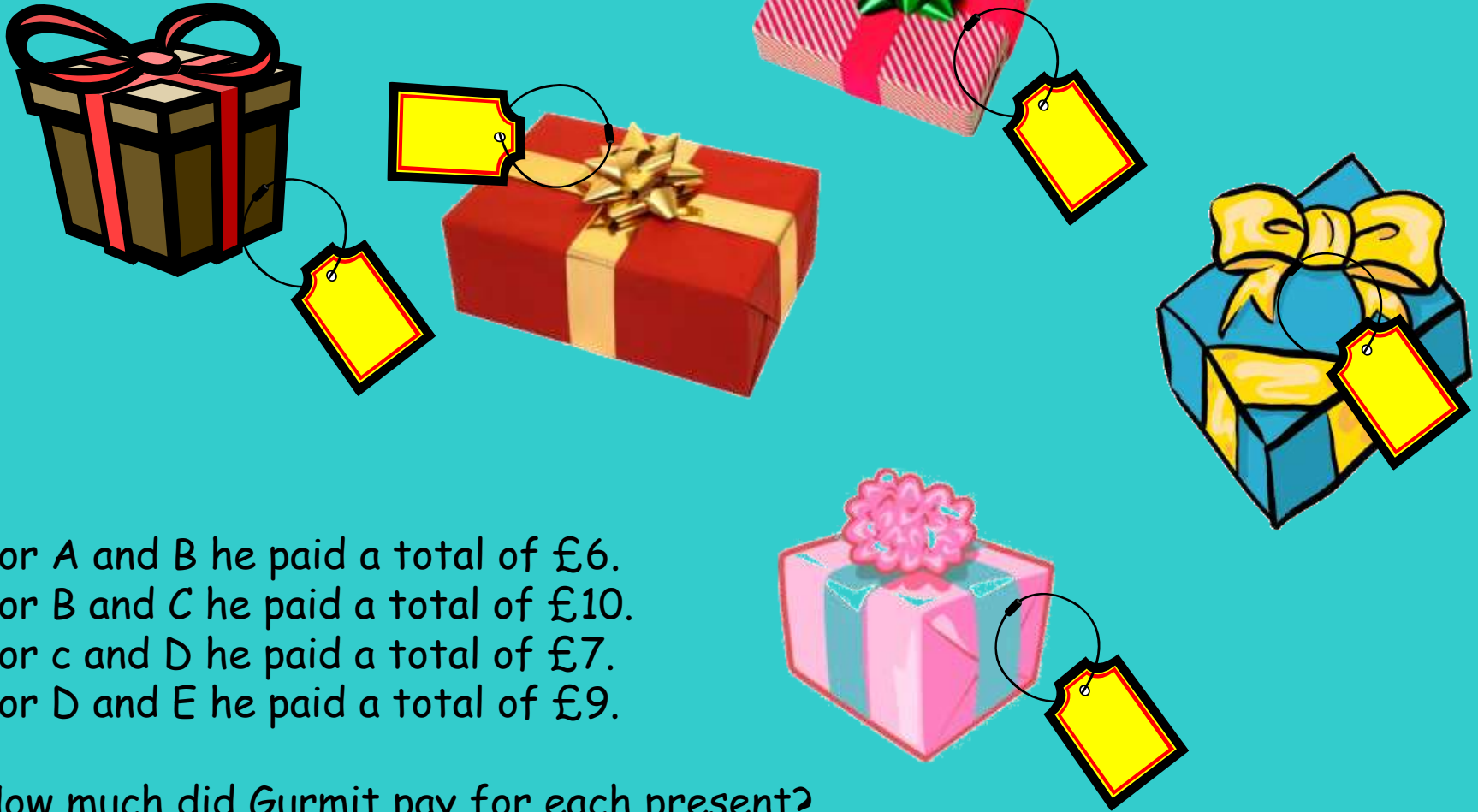

For A and B he paid a total of £6.  
For B and C he paid a total of £10.  
For c and D he paid a total of £7.  
For D and E he paid a total of £9.

How much did Gurmit pay for each present?

Presents Solution



Gurmit paid £2, £4, £6, £1,  
and £8 for the five presents.



## Three digits

Imagine you have 25 beads.

You have to make a three-digit number on an abacus.

You must use all 25 beads for each number you make.

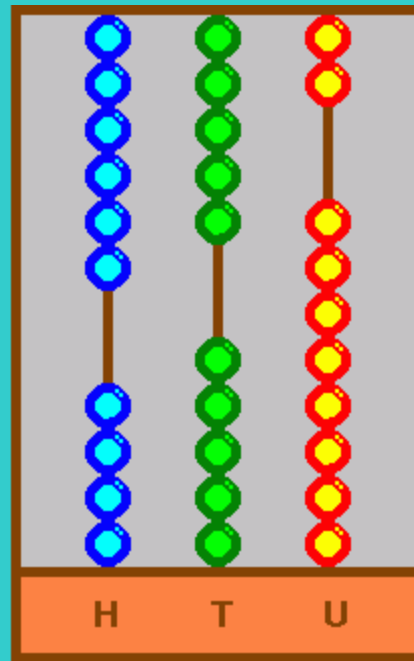

Don't forget you  
can only  
have up to 9  
beads on each  
stick!

How many different three-digit numbers can you make?

Write them in order.

## Three digits Solution

You can make six different numbers.

In order, the numbers are:  
799, 889, 898, 979, 988,  
997.

## Make Five Numbers

Take 10 cards numbered 0 to 9.



Each time use all ten cards.

Arrange the cards to make:

- Five numbers that are multiples of 3
- Five numbers that are multiples of 7
- Five prime numbers

Make up more problems to use all ten cards to make five special numbers.

## Make Five Numbers Solution

a. 12, 39, 45, 60, 78

b. 7, 42, 63, 98, 105

c. 5, 23, 67, 89, 401

There are other solutions.

## Maze

Start with zero.

Find a route from 'start' to 'end' that totals 100

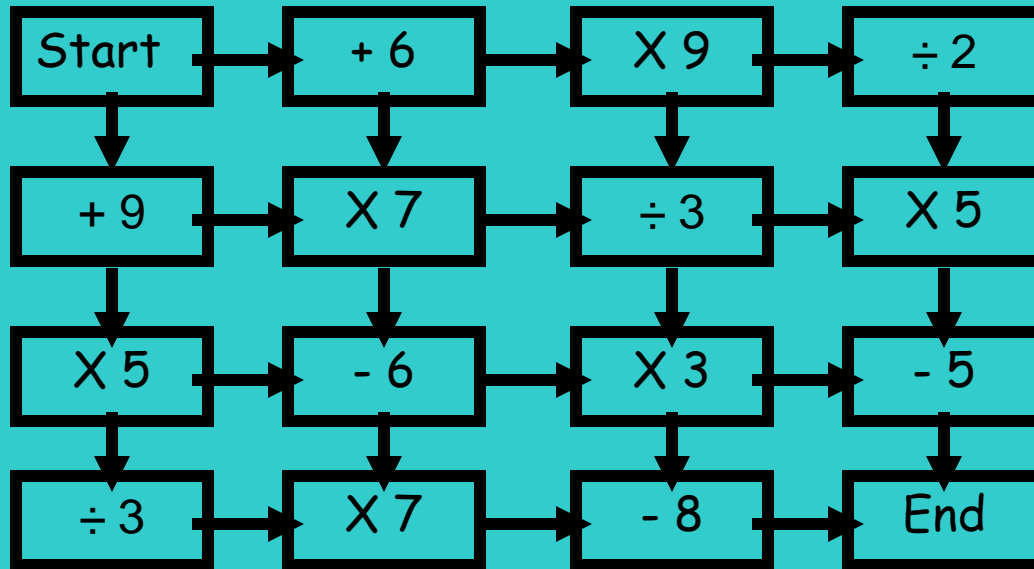

Which route has the highest total?

Which has the lowest total?

Now try some different starting numbers.

## Maze Solution

There are two routes that total 100 exactly:

$$+6 \quad \times 7 \quad -6 \quad \times 3 \quad -8 \quad = 100$$

$$+9 \quad \times 7 \quad \div 3 \quad \times 5 \quad -5 \quad = 100$$

The route giving the highest total is:

$$+9 \quad \times 7 \quad -6 \quad \times 7 \quad -8 \quad = 391$$

The route giving the lowest total is:

$$+6 \quad \times 7 \quad \div 3 \quad \times 3 \quad -8 \quad = 34$$

## Eggs

Mrs Choy spent exactly £10 on 100 eggs for her shop.

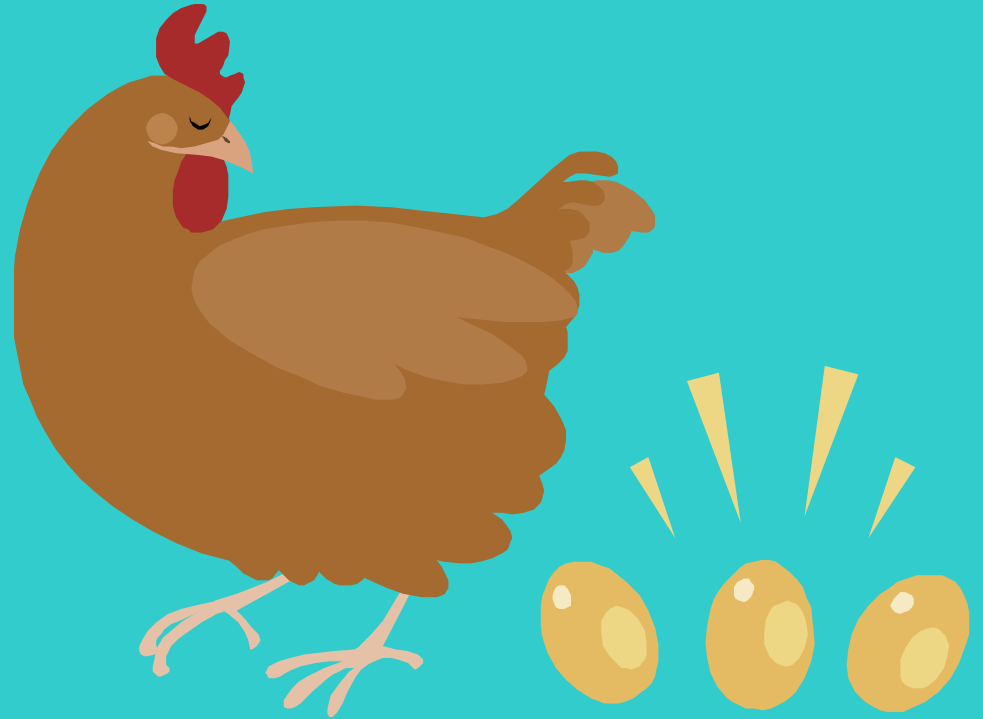

Large eggs cost her 50p each.  
Medium eggs cost her 10p each.  
Small eggs cost her 5p each.

For two of the sizes, she bought the same number of eggs.  
How many of each size did she buy?

## Eggs Solution

Mrs Choy bought:

10 large eggs at 50p each

10 medium eggs at 10p each

80 small eggs at 5p each.

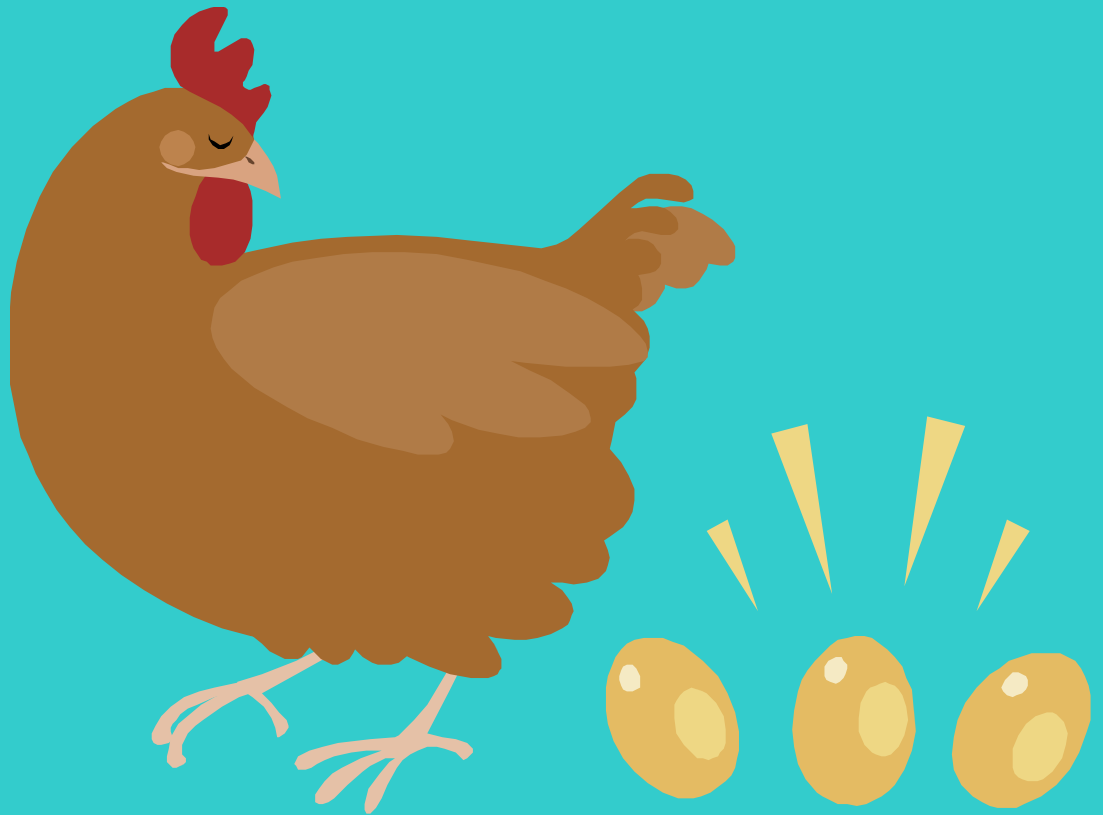

## Flash Harry

In April Flash Harry bought a saddle for £100.

In May he sold it for £200.

In June he was sorry he had sold it.

So he bought it back for £300.

In July he got tired of it.

So he sold it for £400.

Overall, did Flash Harry make or lose money?

How much did he make or lose?



## Flash Harry Solution

Flash Harry's bank balance looked like this:

April - £100

May + £100

June - £200

July + £200

So Harry made £200 overall.



## Age old Problems

1. My age this year is a multiple of 8.  
Next year it will be a multiple of 7.  
How old am I?

2. Last year my age was a square number.  
Next year it will be a cube number.  
How old am I?

How long must I wait until my age is both a square number and a cube?

3. My mum was 27 when I was born. \* years ago she was twice as old as I shall be in 5 years' time.  
How old am I now?

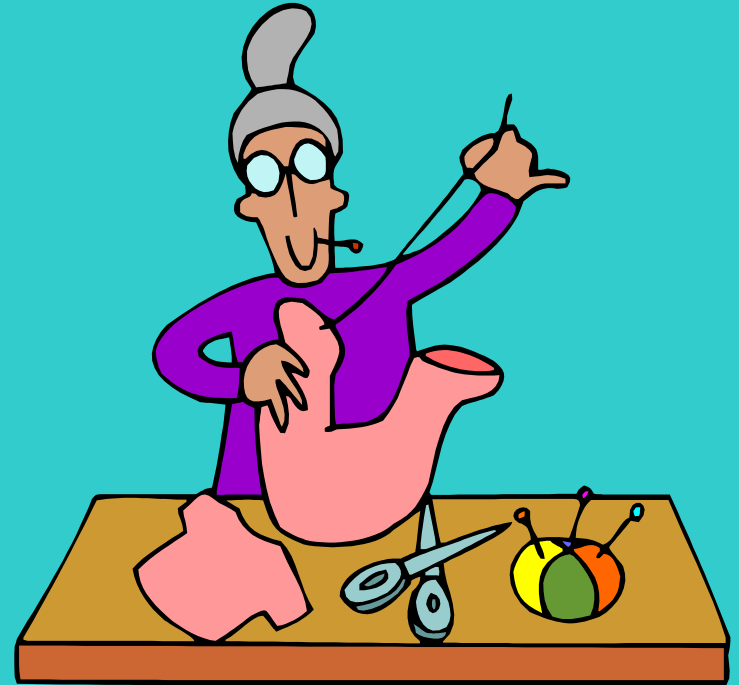

## Age old Problems Solution

1. I am 48 years old (or possibly 104)
2. I am now 26 years old. In 38 years' time, when I am 64, my age will be both a square number and a cube.
3. I am 9 years old now.

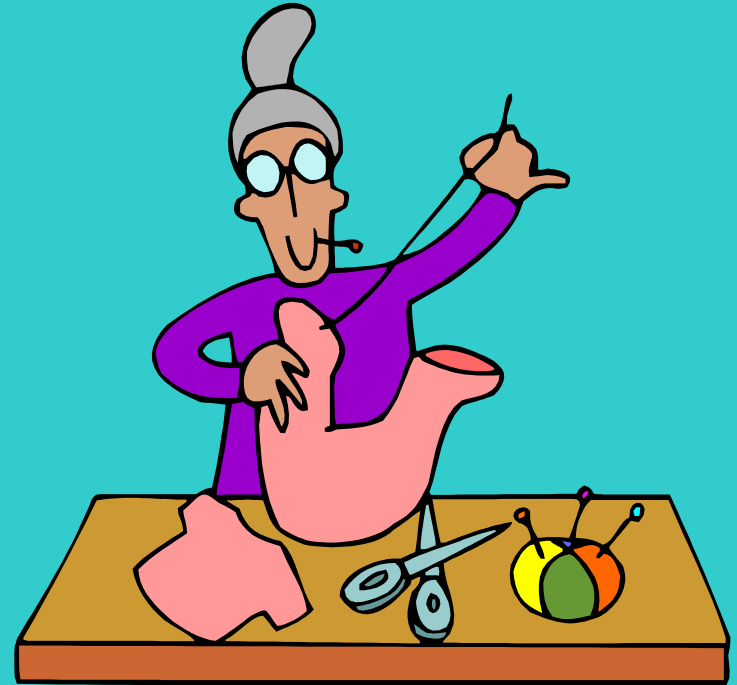

## Zids and Zods

Zids have 4 spots.

Zods have 9 spots.

Altogether some Zids and Zods have 48 spots.

How many Zids are there?

How many Zods?

What if Zids have 5 spots, Zods have 7 spots, and there are 140 spots together?

Find as many solutions as you can.

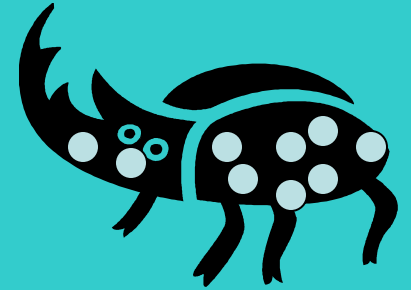
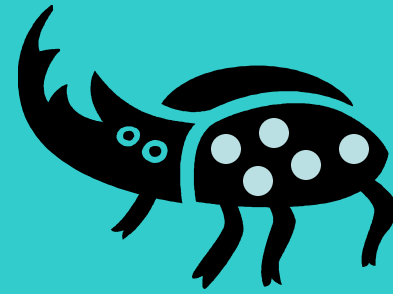

## Zids and Zods Problem Solving Solution

There are 3 Zids with 4 spots and 4 Zods with 9 spots.

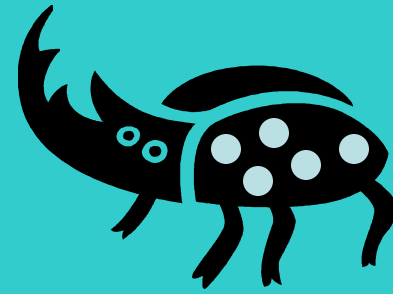

If Zids have 5 spots and Zods have 7 spots, the possible ways of making 140 are:

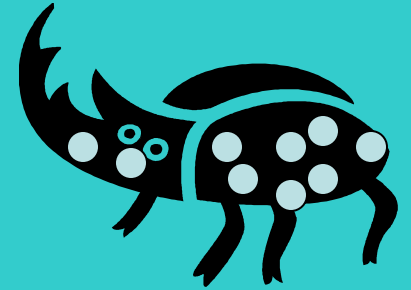

28 Zids;

21 Zids and 5 Zods;

14 Zids and 10 Zods;

1 Zids and 15 Zods;

20 Zods.